

foodproof<sup>®</sup>

# StarPrep<sup>®</sup> Three Kit

*Enterobacteriaceae* plus  
*Salmonella*

## PRODUCT INSTRUCTIONS

Documentation for the rapid DNA extraction from  
*Enterobacteriaceae* enrichment cultures for direct  
use in PCR

Product No. KIT230187 / KIT230188

foodproof®

**StarPrep Three Kit:**

*Enterobacteriaceae* plus  
*Salmonella*

Store kit at 15 to 25 °C  
FOR *IN VITRO* USE ONLY

Product No. KIT230187  
21 mL volume

Product No. KIT230188  
105 mL volume

**Product Instructions**  
Revision A, January 2024

**TABLE OF CONTENTS**

**1. OVERVIEW ..... 4**

**1.1 General Information ..... 4**

**1.2 Applicability..... 4**

**1.3 Kit Contents ..... 5**

**2. INSTRUCTIONS ..... 7**

**2.1 Required Material ..... 7**

**2.2 Precautions and Preparations..... 11**

**2.3 Workflows ..... 11**

    2.3.1 Extraction Procedure A: Standard ..... 12

    2.3.2 Extraction Procedure B: High Throughput..... 14

**2.4. Troubleshooting ..... 17**

**2.5 Support..... 18**

**3. ADDITIONAL INFORMATION ..... 19**

**3.1 General Information ..... 19**

**3.2 Trademarks ..... 20**

**3.3 Reference Number ..... 20**

**3.4 Change Index..... 20**

## OVERVIEW

# 1. OVERVIEW

The foodproof® StarPrep Three Kit is designed for the rapid preparation of DNA from gram-negative bacteria like *Enterobacteriaceae* for direct use in PCR. In less than 30 minutes, preparation with this lysis buffer yields PCR template DNA from enrichment cultures. The extracted DNA can be used directly in any PCR application. The StarPrep Three Lysis Buffer eliminates the need for hazardous organic extractions or chaotropic agents. The entire DNA preparation can be performed in a single tube, minimizing handling steps and exposure to hazardous material. The reduced number of handling steps saves time. Transfer steps of DNA-containing extracts are not necessary, thus cross-contamination risks are minimized.

## 1.1. General Information

### Number of Reactions

The kit is designed for 96 reactions (KIT230187) or 480 reactions (KIT230188).

### Storage Conditions

Store at 15 to 25 °C.

The components of the foodproof StarPrep Three Kit are guaranteed to be stable through the expiration date printed on the label.

## 1.2. Applicability

The lysis buffer is optimized for the preparation of enrichment cultures of various types of sample material, including infant formula with and without probiotics, ingredients and production environment samples. The sample volume varies depending on which matrix is being tested. For very cloudy supernatants, or samples containing inhibitors, a reduction of the sample volume may enhance the DNA isolation efficiency. The quality of the DNA obtained with the lysis buffer is suitable for any PCR application.

## OVERVIEW

### 1.3. Kit Contents

A schematic representation of the foodproof StarPrep Three Kit for the standard and the large version with all its components.

#### KIT230187

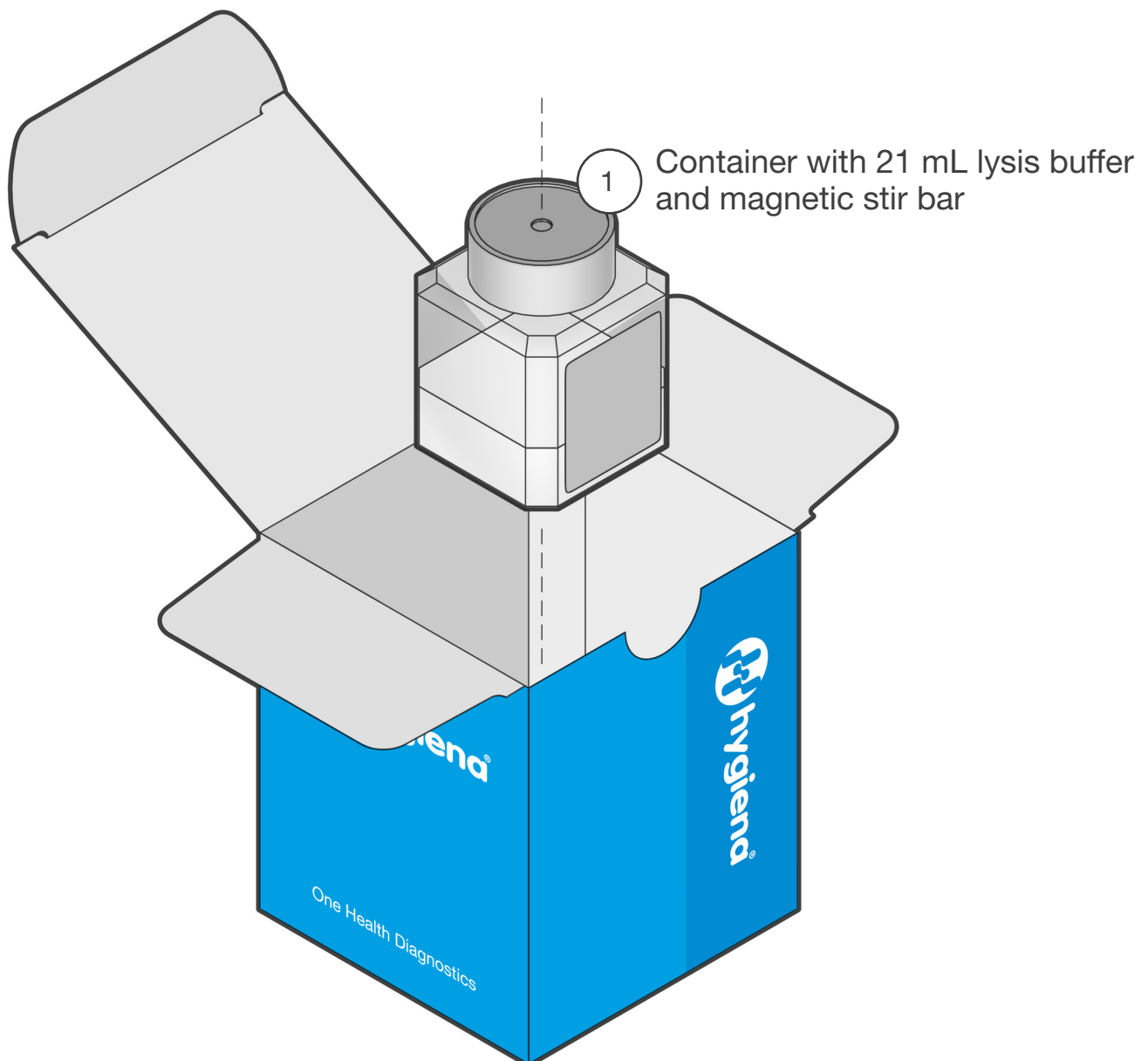

**OVERVIEW**

**KIT230188**

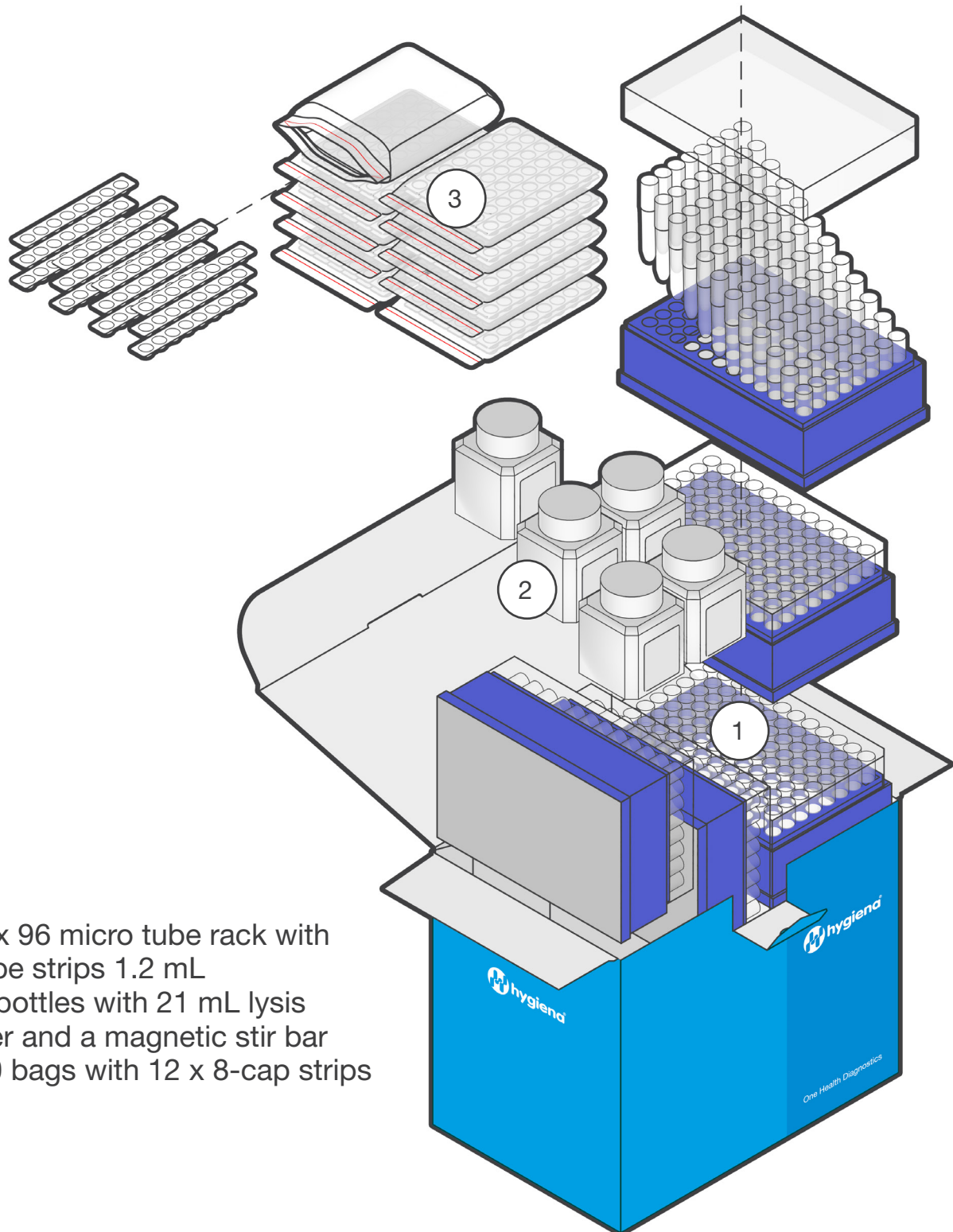

- 1. 5 x 96 micro tube rack with 8-tube strips 1.2 mL
- 2. 5 bottles with 21 mL lysis buffer and a magnetic stir bar
- 3. 10 bags with 12 x 8-cap strips

## INSTRUCTIONS

# 2. INSTRUCTIONS

This section provides all information for a seamless DNA extraction from a variety of matrices.

## 2.1. Required Material

Most of the required equipment and reagents are available through Hygiena®. Please contact us for further information.



*It is highly recommended only to use the materials described below to guarantee the robustness of the method.*

---

### Reagents

---

**Reagent D**

≤ 48 reactions: Product No. KIT230003 (15 mL)

≤ 96 reactions: Product No. KIT230001 (30 mL)

Up to 480 reactions: Product No. KIT230002 (150 mL)

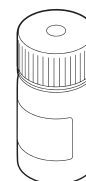

## INSTRUCTIONS

---

### Equipment for procedure A: Standard

---

- Standard tabletop **microcentrifuge** capable of a 13,000 × g centrifugal force

*e.g., Micro Star 17 - VWR*

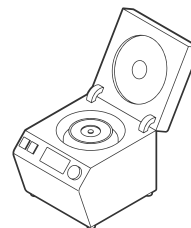

- Heating unit** suitable for 1.5 mL tubes

*e.g., AccuBlock™ - Labnet with heating block*

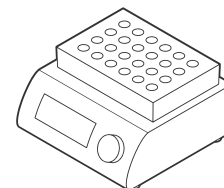

- Vortex mixer**

*e.g., Vortex Genie - Scientific Industries*

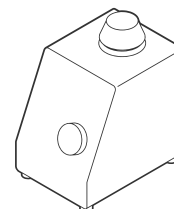

- D-Light**

*Product No. MCH230009*

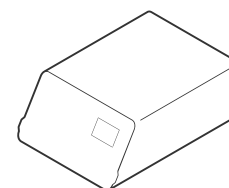

### Recommended:

- Magnetic Stirrer**

*e.g., Color Squid IKAMAG® - IKA®-Werke*

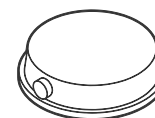



**INSTRUCTIONS**

---

**Equipment for procedure B: High Throughput**

---

- Multichannel pipette** and filter tips for 50 to 1,250  $\mu\text{L}$   
e.g., 8-Channel Pipette Viaflo - INTEGRA Biosciences with GripTips: 50 to 1,250  $\mu\text{L}$   
or EP Xplorer Plus Electronic Multichannel Pipette with Filter Tips: 50 to 1,250  $\mu\text{L}$



- Centrifuge** with swing-out rotor for microtiter plates capable of a 2,000  $\times$  g centrifugal force  
e.g., Sigma 2-7 including rotor

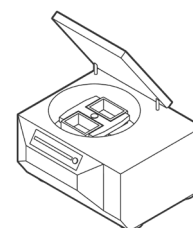

- TH 21 heating block thermostat**

- Exchange block for deepwell plates for TH 21

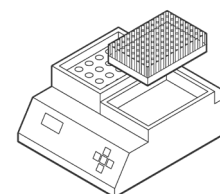

- Lid weight** with **incubation frame** for TH 21 heating block thermostat

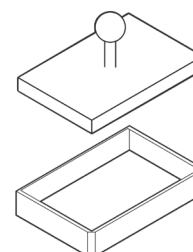

- D-Light**  
Product No. MCH230009

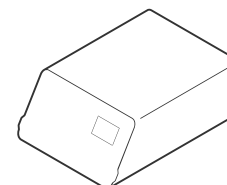

- Decapper 8-strip**

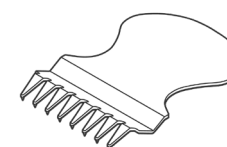

## Recommended:

- Magnetic stirrer**  
*e.g., Color Squid Wave - IKA®-Werke*

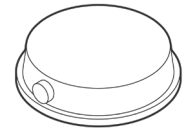

- Cap installing tool**

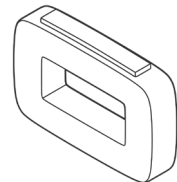

---

## Consumables for procedure B: High Throughput

---

- Deep well plate**, 96 well, square well, PP, 1 mL

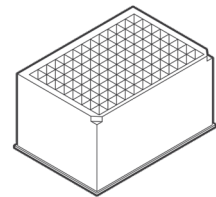

- Sterile reservoir**  
*25 mL or 100 mL*

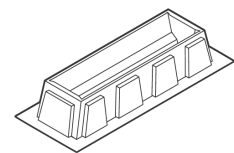

**INSTRUCTIONS****2.2. Precautions and Preparations**

Follow all universal safety precautions governing work with biohazardous materials, e.g., wear lab coats and gloves at all times. Properly dispose of all contaminated materials, decontaminate work surfaces, and use a biosafety cabinet whenever aerosols might be generated.

For more information, please refer to the appropriate safety data sheet (SDS). The SDS is available online at [www.hygiena.com](http://www.hygiena.com).

- Always use filter tips in order to avoid cross-contamination.

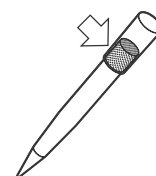

- Mix thoroughly while pipetting the buffer for sample preparation. It is not recommended to use more than 96 reactions per 50 mL bottle. The container must retain some of the reagent.

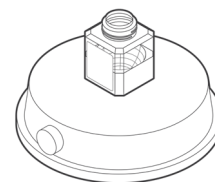

- Set the heating unit to 95 to 100 °C.

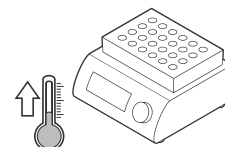

- Thaw the Reagent D prior to use. Avoid more than three (3) freeze-thaw cycles. If necessary, aliquots can be prepared and stored according to the Reagent D manual. Avoid extended exposure to light.

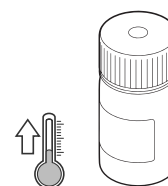
**2.3. Workflows**

The following procedures describe the DNA isolation from enrichment cultures. Depending on sample size, two protocols for small sample quantities (Procedure A: Standard) and high sample quantities (Procedure B: High Throughput) are available. Both protocols include a live/dead discrimination step using Reagent D. The High-Throughput Extraction procedure uses 8-strip tubes and multichannel pipettes are recommended, when more than 16 samples are processed.

**INSTRUCTIONS****2.3.1. EXTRACTION PROCEDURE A: STANDARD**

This protocol is intended for extracts that will be used in combination with foodproof kits, including *Enterobacteriaceae* in combination with other parameter, e.g., *Salmonella* or *Cronobacter*. A step for live and dead cell differentiation with Reagent D is included.

**1. SHAKE SAMPLE**

Shake enrichment culture gently and let the suspension settle for 5 to 10 min.

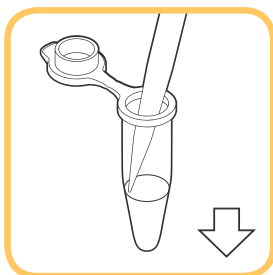
**2. ADD REAGENT D**

Transfer **300 µL** Reagent D to a transparent 1.5 mL reaction tube.

*Note: Proceed immediately with the following steps of the protocol. Avoid extended exposure to light.*

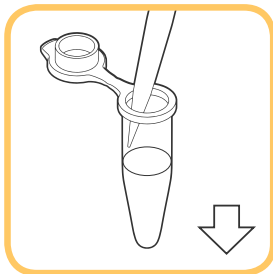
**3. ADD SAMPLE**

Transfer **100 µL** sample (enrichment culture supernatant) to the reaction tube. **Mix thoroughly** by pipetting up and down.

*Note: For very cloudy supernatants, a reduction of the sample volume (e.g., 50 µL) might enhance the DNA isolation efficiency.*

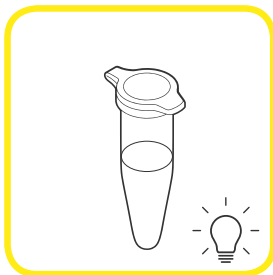
**4. D-LIGHT TREATMENT**

Incubate for **5 min at room temperature** in the D-Light **in the dark**.

Incubate for **5 min at room temperature** in the D-Light **with light exposure**.

**5. CENTRIFUGE**

**5 min at 8,000 x g.**

*Note: If the enrichment cultures are totally clear, centrifugation at > 13,000 x g is recommended.*

## INSTRUCTIONS

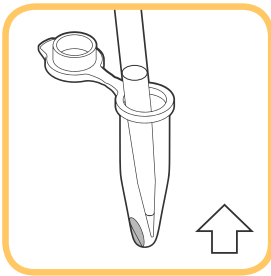

### 6. REMOVE SUPERNATANT

Discard liquid with a pipette immediately after centrifugation and inactivate appropriately.

*Note: Take care that the tip of the pipette is on the opposite side of the pellet during pipetting.*

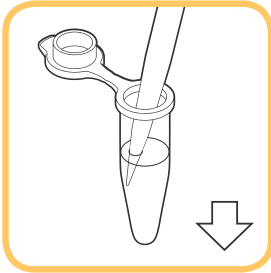

### 7. ADD LYSIS BUFFER

Transfer **200 µL** lysis buffer to the sample tube and resuspend the pellet by vortexing or by pipetting gently up and down.

*Note: For optimal DNA isolation efficiency, pellet has to be completely resuspended. Use a magnetic stirrer (low speed) or briefly shake the bottle gently before pipetting the lysis buffer to avoid sedimentation of ingredients.*

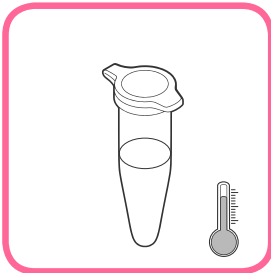

### 8. INCUBATE

**10 min at 95 to 100 °C** in a heating unit.

Carefully remove the reaction tube from the heating unit and allow the tube to sit for **1 min at 15 to 25 °C**.

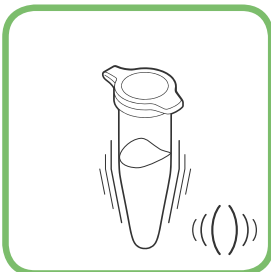

### 9. MIX

**Vortex for 2 s.**



### 10. CENTRIFUGE

**2 min at 13,000 x g.**

*Note: If necessary, centrifugation forces should be calculated according to the respective centrifuge user manual.*

## SUPERNATANT FOR DETECTION

**Use extract for the foodproof PCR kits.**

*Strictly avoid transferring fractions of the sediment to the PCR reaction, because this might cause PCR inhibition.*

**For later analysis, store DNA at -15 to -25 °C.**

*After thawing, mix briefly by vortexing and centrifuge at 13,000 x g for 2 min.*

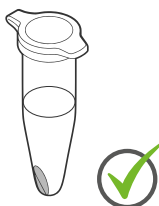

## INSTRUCTIONS

### 2.3.2. EXTRACTION PROCEDURE B: HIGH THROUGHPUT

This high-throughput protocol is recommended for the detection of *Enterobacteriaceae*, or *Enterobacteriaceae* in combination with other parameters, e.g., *Salmonella* or *Cronobacter*.

A step for live and dead cell differentiation with Reagent D is included.



#### 1. SHAKE SAMPLE

Shake enrichment culture gently and let suspension settle for 5 to 10 min.

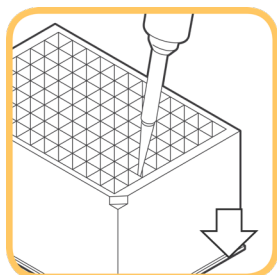

#### 2. ADD SAMPLE

Transfer **100 µL** sample (enrichment culture supernatant) to the 96 deep well plate.

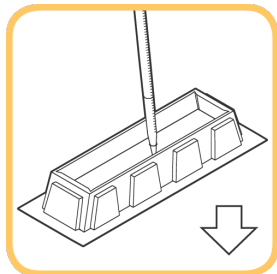

#### 3. PREPARE REAGENT D

Transfer an adequate volume of **Reagent D** in a sterile reservoir: **300 µL** per sample plus **1 mL** as dead volume.

*Note: The lights in the clean bench must be switched off. Proceed immediately with the following steps of the protocol. Avoid extended exposure to light.*

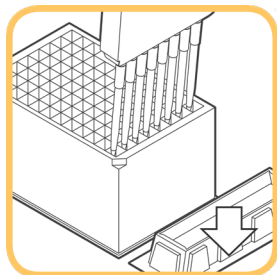

#### 4. ADD REAGENT D AND MIX

Using a multichannel pipette, transfer **300 µL Reagent D** to each well of the deep well plate. **Resuspend pellets** by pipetting up and down 5 times.

*Note: For optimal DNA isolation efficiency, pellet has to be completely resuspended. For uptake of Reagent D and mix, pipet with maximum speed of the automatic pipette. Proceed immediately with the following steps of the protocol. Avoid extended exposure to light.*

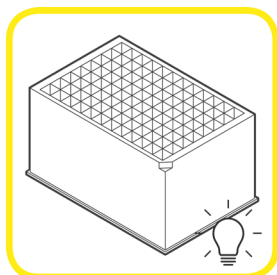

#### 5. D-LIGHT TREATMENT

Place the 96 deep well plate in the **D-Light** unit. Incubate first **in the dark for 5 min** and subsequently **expose to light for 5 min** at room temperature in the D-Light unit.

## INSTRUCTIONS

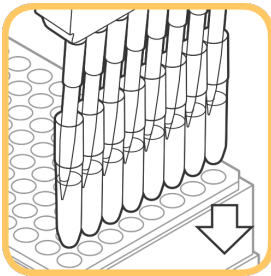

### 6. TRANSFER VOLUME

First, **resuspend 5 times** and then transfer the whole volume (400  $\mu$ L) with a multichannel pipette from the 96 deep well plate to 8-tube strips.

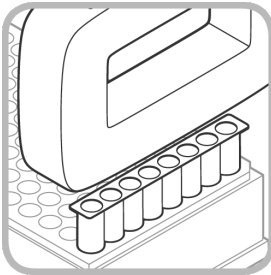

### 7. SEAL TUBES

Seal the 8-tube strips **tightly** with sterile cap strips.

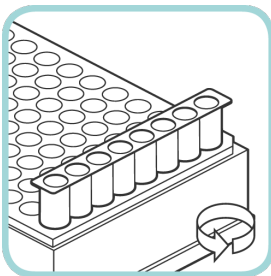

### 8. CENTRIFUGE

**10 min at 5,400 x g** (or 25 min at 2,000 x g).

Make sure the rack is not sealed with rack lid during centrifugation.

*Note: Time and g-force depend on the centrifuge (please see 2.1. Required Material for more information). Set the centrifuge acceleration to maximum speed and the brake to medium. If necessary, centrifugation forces should be calculated according to the respective centrifuge user manual.*

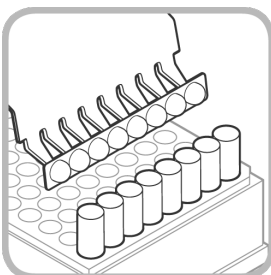

### 9. REMOVE CAPS

Remove and discard the 8-cap strips from the 8-tube strips.  
To minimize the contamination risk, use the decapper 8-strip tool.

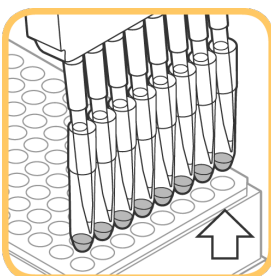

### 10. REMOVE SUPERNATANT

Immediately after centrifugation, remove supernatant carefully with a multichannel pipette, discard liquid and inactivate appropriately.

Take care that the tips of the pipette are not touching the pellets in the reaction tubes.

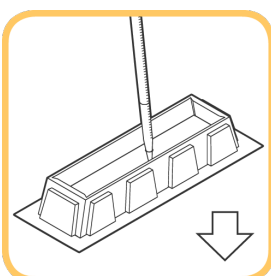

### 11. PREPARE LYSIS BUFFER

Transfer required lysis buffer to a sterile reservoir.

**200  $\mu$ L** lysis buffer per sample plus **1 mL** lysis buffer as dead volume.

*Note: Use a magnetic stirrer (low speed) or shake the bottle with lysis buffer gently in a short time interval to avoid sedimentation of ingredients.*

## INSTRUCTIONS

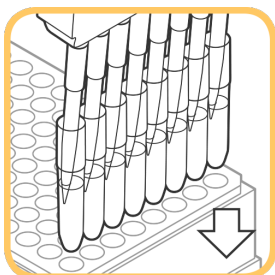

### 12. ADD LYSIS BUFFER AND MIX

Pipet lysis buffer up and down 5 to 10 times in reservoir before using it to avoid sedimentation of ingredients.

Transfer **200 µL** lysis buffer with a multichannel pipette to each tube.

**Resuspend pellets** by pipetting up and down 5 to 10 times.

*Note: For optimal DNA isolation efficiency, pellet has to be completely resuspended.*

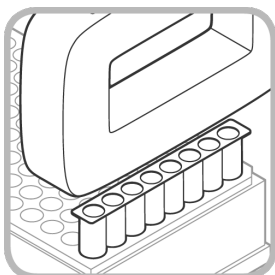

### 13. SEAL TUBES

Seal the tubes **tightly** with **new** sterile cap strips.

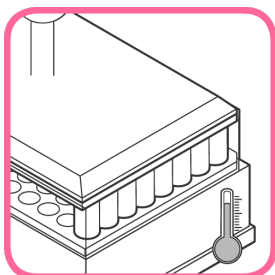

### 14. INCUBATE

**Remove tube rack bottom and install incubation frame.**

Incubate rack with tube stripes **10 - 15 min at 100 °C**

in TH 21 Heating Block for 8-tube strips.

Weight caps down with the lid weight.

*Note: To avoid removing and reinstalling the bottom, tube strips can be placed in an empty microcentrifuge tube rack (with rack bottom removed).*

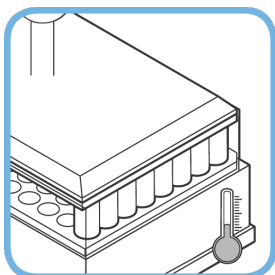

### 15. CHILL

Carefully **remove** the rack with the **tube strips together with the lid weight** from the heating unit and let it **cool 3 - 5 min at room temperature**.

To avoid opening of caps, do not remove the lid weight until the strips have cooled down.

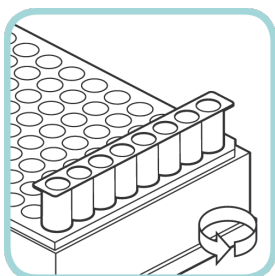

### 16. CENTRIFUGE

**Reinstall tube rack bottom.**

Centrifuge **5 min at 5,400 x g** (or 10 min at 2,000 x g).

Make sure the rack is not sealed with rack lid during centrifugation.

## SUPERNATANT FOR DETECTION

**Use up to 25 µL of the extract for the respective foodproof PCR Kits.**

*Note: Strictly avoid transferring fractions of the sediment to the PCR reaction because this might cause PCR inhibition.*

**For later analysis, store DNA at -15 to -25 °C.**

After thawing, mix briefly by vortexing and centrifuge at 2,000 x g for 10 min.

*Note: The sample is not purified. Proteins, RNA, and other materials remain in the sample. Long-term storage or archival of prepared DNA samples is not recommended.*

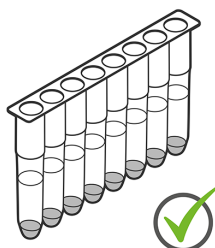



## TROUBLESHOOTING

## 2.4. Troubleshooting

Problem	Possible Cause	Recommendation
Extract inhibits PCR	Enrichment culture or sample contains too many PCR inhibitors.	Perform a subcultivation, e.g., 1:10 dilution in fresh enrichment broth. Repeat DNA extraction with a reduced sample volume. For very cloudy supernatants, a reduction of the sample volume might enhance DNA isolation efficiency.
	DNA extract contains too many PCR inhibitors.	Dilute DNA extract, e.g., 1:10, or reduce the amount of extracted DNA, e.g., for LyoKits 5 µL + 20 µL PCR-grade H <sub>2</sub> O instead of 25 µL.
	Some of the centrifugation pellet transferred over to the PCR.	Always centrifuge the DNA sample before performing PCR. Use the top of the supernatant as a PCR template. Do not allow the filter tip to make contact with the pellet.
	Supernatants are not completely removed.	Remove supernatants completely.
Low DNA yield	Improper storage of kit components.	Store kit reagents at 15 to 25 °C.
	Enrichment culture contains substances that reduce the DNA extraction efficiency.	Perform a subcultivation or dilution, e.g., 1:10 in fresh enrichment broth.
	Sample contains substances that reduce the DNA extraction efficiency.	Reduce the sample volume. Important note: this will also reduce sensitivity.
	Not enough target organisms in enrichment culture.	Prolong the incubation phase.
	Pellet resuspension incomplete.	Improve resuspension by prolonged pipetting or vortexing.
	Suboptimal reaction conditions.	Ensure proper heating conditions. Verify correct temperature of the heating block with a thermometer.
Lid of the reaction tube opens during or after heating	Reaction tube not firmly closed or not enough weight exerted on the caps of the tube strips.	Ensure that all reaction tubes are firmly closed before heating. Weigh the caps down during heating and do not remove the weight until the tubes have cooled down.

## INSTRUCTIONS

### 2.5. Support

If you have questions or experience any problems with our products, please contact us:



[www.hygiena.com/support](http://www.hygiena.com/support)

Our aim is to provide you with a solution as quickly and effectively as possible. We would also like you to contact us if you have any suggestions for improving the product or in case you would like to use our product for a different application. We highly value your feedback.

**ADDITIONAL INFORMATION**

## 3. ADDITIONAL INFORMATION

### 3.1 General Information

#### Quality Control

All products are regularly monitored by our quality control. You can find the certificate of analysis (COA) on our website. If you would like to carry out your own quality control, you will find the analysis method described in the certificate.

#### Waste Disposal

All contaminated and potentially infectious material, like enrichment cultures or food samples, should be autoclaved before disposal and eliminated according to local rules and regulations. For proper disposal of unused chemicals, please refer to the SDS.

#### Warranty and Disclaimer of Liability

“Limited Warranty” and “Disclaimer of Liability”: Hygiena Diagnostics GmbH warrants that this product is free from defects in materials and workmanship through the expiration date printed on the label and only if the following are complied with:

- (1) The product is used according to the guidelines and instructions set forth in the product literature;
- (2) Hygiena Diagnostics GmbH does not warrant its product against any and all defects when: the defect is as a result of material or workmanship not provided by Hygiena Diagnostics GmbH; defects caused by misuse or use contrary to the instructions supplied, or improper storage or handling of the product;
- (3) All warranties of merchantability and fitness for a particular purpose, written, oral, expressed or implied, shall extend only for a period of one year from the date of manufacture. There are no other warranties that extend beyond those described on the face of this warranty;
- (4) Hygiena Diagnostics GmbH does not undertake responsibility to any purchaser of its product for any undertaking, representation or warranty made by any dealers or distributors selling its products beyond those herein expressly expressed unless expressed in writing by an officer of Hygiena Diagnostics GmbH;
- (5) Hygiena Diagnostics GmbH does not assume responsibility for incidental or consequential damages, including, but not limited to responsibility for loss of use of this product, removal or replacement labor, loss of time, inconvenience, expense for telephone calls, shipping expenses, loss or damage to property or loss of revenue, personal injuries or wrongful death;
- (6) Hygiena Diagnostics GmbH reserves the right to replace or allow credit for any modules returned under this warranty.

## ADDITIONAL INFORMATION

### 3.2 Trademarks

foodproof®, microproof®, vetproof®, ShortPrep®, StarPrep®, RoboPrep® and LyoKit® are registered trademarks of Hygiena Diagnostics GmbH.

Hygiena® is a registered trademark of Hygiena.

Other brand or product names are trademarks of their respective holders.

### 3.3 Reference Number

The reference number and original Hygiena Diagnostics GmbH article numbers: S 400 18 (KIT230187) and S 400 18 L (KIT230188).

### 3.4 Change Index

*Version 1, April 2021:*

New document.

*Revision A, January 2024:*

Rebrandng, new document layout and updated content.

S 400 18 20 -> INS-KIT-230187-88-4-RevA

**Hygiena®**

Camarillo, CA 93012  
USA

[diagnostics.support@hygiena.com](mailto:diagnostics.support@hygiena.com)

**Manufactured by**

**Hygiena Diagnostics GmbH**

Hermannswerder 17  
14473 Potsdam  
Germany

[www.hygiena.com](http://www.hygiena.com)